

# Sex Expression of Staminate Cluster as Affected by Pinching the Main Shoot, Defoliation and N<sup>6</sup>-benzylaminopurine in Monoecious Cucumber

Kanapol Jutamane, Takashi Saito, Kouki Kanchama, Kiyotoshi Takeno<sup>1</sup> and Suranant Subhadrabandhu<sup>2</sup>

## ABSTRACT

Effects of pinching the main shoot, defoliation and N<sup>6</sup>-benzylaminopurine (BA) on sex expression in cucumber were investigated by using a qualitative cucumber, cv. Sagami-hanjiro. Pinching main shoot induced development of bisexual, pistillate flowers and lateral shoots. Direct application of BA to the staminate cluster at node 4 or 7 induced pistillate flower development only on that cluster, especially on that at the node 4. The defoliation by allowing one leaf remained in the plant decreased the total numbers of flower of all sexes. However, the defoliation with one leaf remaining at node 4 or 7 gave the same total numbers of staminate, bisexual, pistillate flowers and lateral shoots when compared with those at the corresponding nodes in the control plants. The reduction of leaf area to half or quarter had no effect on the total numbers of staminate and bisexual flowers, but this method decreased the total numbers of pistillate flowers.

**Key words :** sex expression, pinching, defoliation, N<sup>6</sup>-benzylaminopurine, cucumber

## INTRODUCTION

The monoecious cucumber (*Cucumis sativus* L.), cv. 'Sagami-hanjiro' produces staminate flowers as a cluster at the lower node and pistillate flowers at the higher part. Jutamane and Saito (1992) showed that sex expression of this cultivar depended on photoperiod, growth regulators and number of leaves. Decrease the number of leaves by defoliation inhibited pistillate flowers formation in many cultivars of cucumber plants (Saito *et al.*, 1988). Furthermore, pinching the main shoot of *Luffa cylindrica* induced bisexual and pistillate flowers formation (Takahashi *et al.*, 1980). Decapitation also induced flowering of axillary buds which release from apical dominance in *Leucospermum* plant (Jacobs, 1983). Axillary bud growth is controlled by auxin from the shoot and lateral organ (Tamas, 1987). Exogenous cytokinin is known to release the inhibition of growth of lateral bud caused by apical dominance as well as removal of the main shoot apex (Sachs and Thimann, 1967). The mechanism of apical dominance is partly an antagonism between auxin and cytokinin (Thimann *et al.*, 1971).

Cytokinin such as N<sup>6</sup>-benzylamino-9-(tetrahydro-2-pyryl)-purine (PBA), N<sup>6</sup>-benzylaminopurine (BA) and zeatin induced femaleness in *Vitis vinifera* (Negi and Olmo, 1971), *Cannabis sativa* (Chailakhyan and Khryanin, 1978a; 1978b), *Cleome iberidella* (De Jong and Bruinsma, 1974), *Asparagus officinalis* (Lazarte and Garrison, 1980) and *Luffa cylindrica* (Takahashi *et al.*, 1980). Furthermore, endogenous cytokinin was found higher in female plants of *Asparagus officinalis* (Ombrello and Garrison, 1987), *Cannabis sativa* and *Spinacia oleracea* (Khryanin and Chailakhyan, 1979).

The objective of these experiments was to study the mechanism of transformation of the primordia of staminate flower cluster which released from apical dominance by pinching the main shoot, defoliation and the application of BA.

## MATERIAL AND METHODS

### Plant material

The seeds of cucumber (*Cucumis sativus*), cv. 'Sagami-hanjiro' were soaked in water and left in

<sup>1</sup> Lab. of Horticulture, Faculty of Agriculture, Tohoku University, Sendai 981 Japan.

<sup>2</sup> Dept. of Horticulture, Faculty of Agriculture, Kasetsart University, Bangkok 10900 Thailand.

darkness at 30 °C for one night. The germinated seeds were planted in 10 cm diameter plastic pots containing soil with 15N-15P-15K fertilizer. Watering and fertilization were done according to ordinary cultural practices. The experimental treatments were started when the plants reached 7th leaf stage. Leaves, flowers and lateral shoots at node 1 to 3 were removed. Ten plants were used for each treatment.

#### Effect of pinching

The experiment was conducted during June and August, 1991. The main shoot was pinched between node 7 and node 8 or without pinching. Newly developed lateral shoots were also removed in a half of the pinched plants. All of the treatments were illustrated in Figure 1 (A to C).

#### Effect of BA

The experiment was conducted from July to September, 1992. The main shoot was pinched and lateral shoots were removed as in the first experiment. BA was applied to the staminate cluster at node 4 or 7 as shown in Figure 1 (C to E). One cm<sup>2</sup> cotton was

immersed to 100 ppm solution of BA and placed on the staminate cluster. The treatments were repeated with 3-day interval during 30 days.

#### Effect of leaf number and its position.

The experiment was conducted at the same time as the second experiment. The main shoot was pinched and lateral shoots were removed as in the first experiment. All the leaves but one leaf at node 4 or node 7 were removed as shown in Figure 1 (C, F and G.)

#### Influence of leaf area.

The experiment was conducted from September to November, 1990. The main shoot was pinched and the lateral shoots at every node were removed in the same manner as in the first experiment. Leaves were trained remaining half or quarter of area or kept intact as shown in Figure 1 (C, H and I). Leaves were cut along the midrip so that a half of area remained. These leaves were then cut into half again for treatment of quarter of leaves area.

Numbers of staminate, bisexual, pistillate flow-

**Table 1 Effect of pinching main shoot on sex expression of staminate cluster in cucumber, cv. "Sagami-hanjiro".<sup>Z</sup>**

Treatment	Node <sup>Y</sup>	Total number of				Total
		staminate flowers	bisexual flowers	pistillate flowers	new lateral shoots	
Intact	7	81±1.02	5±0.21	1±0.09	0±0.00	87±1.23
	6	50±1.02	2±0.12	0±0.00	0±0.00	52±1.05
	5	56±1.64	10±0.32	0±0.00	0±0.00	66±1.89
	4	50±1.18	10±0.31	0±0.00	0±0.00	60±1.39
	Total	237±4.02	27±0.55	1±0.09	0±0.00	265±4.30
Pinching	7	72±1.35	16±0.47	1±0.09	89±1.77	<sup>x</sup>
	6	47±1.02	22±0.40	1±0.09	77±1.14	
	5	56±1.28	21±0.56	0±0.00	70±1.68	
	4	60±1.28	24±0.71	0±0.00	84±1.64	
	Total	235±2.51	83±1.34	2±0.13	320±2.70	
Pinching and lateral shoots removed <sup>W</sup>	7	67±1.45	48±1.41	1±0.09	11±0.22	127±2.53
	6	48±0.75	43±0.53	5±0.29	13±0.20	109±0.03
	5	55±1.11	58±1.24	4±0.21	13±0.25	130±2.17
	4	57±1.50	56±1.65	1±0.09	12±0.28	126±3.03
	Total	227±3.95	205±3.43	11±0.39	49±0.57	502±7.04

<sup>Z</sup> The values are total numbers per 10 plants of flowers of each sex or lateral shoot ± SE.

<sup>Y</sup> Counted from the lower part.

<sup>X</sup> Not observed.

<sup>W</sup> Ordinary lateral shoot was removed.

ers and lateral shoots developed on each node 4 to 7 on the main shoot were collected and observed.

## RESULTS

### Effect of pinching

The intact plants produced many staminate flowers and a few pistillate flowers between nodes 4 and 7 (Table 1). Pinching of the main shoot stimulated development of bisexual flowers, especially in the absence of lateral shoot treatment where development of pistillate flowers was also stimulated. The pinching induced the development of lateral shoots. Lateral shoot induced by pinching was formed at the position of staminate flower cluster (Figure 2). The size of staminate flowers in all treatments of pinching increased as compared to the non-pinching treatment (Data did not show).

### Effect of BA

BA application to the staminate cluster of pinching plants promoted pistillate flowers formation (Table 2). BA was effective on increasing pistillate flow-

ers only in the cluster to which BA was applied, especially in that at the node 4.

### Effect of leaf number and its position on main shoot

The defoliation by allowing one leaf intact to the plant decreased the total numbers of staminate, bisexual, pistillate flowers and lateral shoots (Table 3). When the number of flower of each sex at individual nodes was scored, the treatment with a leaf remaining at the node 7 resulted in almost the same total numbers of staminate, bisexual, pistillate flowers and lateral shoots as those in the node 7 of the control plants. Similarly, the plant with a leaf at the node 4 produced almost the same numbers of staminate, bisexual, pistillate flowers and lateral shoots as in the node 4 of the control plants.

### Influence of leaf area

The trimming of the leaves to half or quarter had no effect on the total numbers of staminate and bisexual flowers and lateral shoots (Table 4). However, this treatment decreased the total numbers of pistillate flowers. Pistillate flowers were formed at the

**Table 2 Effect of application BA at the flower clusters on sex expression of staminate cluster in cucumber, cv. "Sagami-hanjiro".<sup>Z</sup>**

Application of BA (Position)	Node <sup>Y</sup>	Total number of				Total
		staminate flowers	bisexual flowers	pistillate flowers	new lateral shoots	
-	7	62+-0.71	54+-1.94	3+-0.30	6+-0.16	125+-2.92
	6	41+-0.30	35+-0.71	3+-0.15	9+-0.18	88+-1.24
	5	39+-0.38	30+-1.26	4+-0.30	11+-0.23	84+-1.39
	4	35+-0.40	30+-0.85	5+-0.49	10+-0.15	80+-1.24
	Total	177+-0.83	149+-2.27	15+-0.49	36+-0.35	377+-2.93
+X (Node 7)	7	59+-1.21	50+-1.14	6+-0.21	7+-0.15	122+-1.66
	6	40+-0.86	32+-0.80	4+-0.21	10+-0.15	86+-1.45
	5	37+-0.33	29+-0.41	5+-0.22	14+-0.16	85+-0.68
	4	30+-0.82	32+-0.80	5+-0.22	11+-0.18	78+-1.78
	Total	166+-1.95	143+-0.80	20+-0.45	42+-0.28	371+-3.85
+ (Node4)	7	55+-0.37	44+-1.24	3+-0.15	6+-0.15	108+-1.67
	6	40+-0.86	32+-0.80	4+-0.21	10+-0.15	86+-1.39
	5	43+-0.84	32+-0.07	6+-0.30	11+-0.17	92+-1.76
	4	35+-0.42	31+-0.33	10+-0.23	8+-0.13	84+-0.57
	Total	168+-0.97	143+-1.66	23+-0.49	35+-0.41	373+-2.80

Z All the plants were pinched above the 7th node and the values are total numbers per 10 plants of flowers of each sex or lateral shoot  $\pm$  SE.

Y Counted from the lower part.

X BA at 100 ppm was applied for 10 times every 3 days.

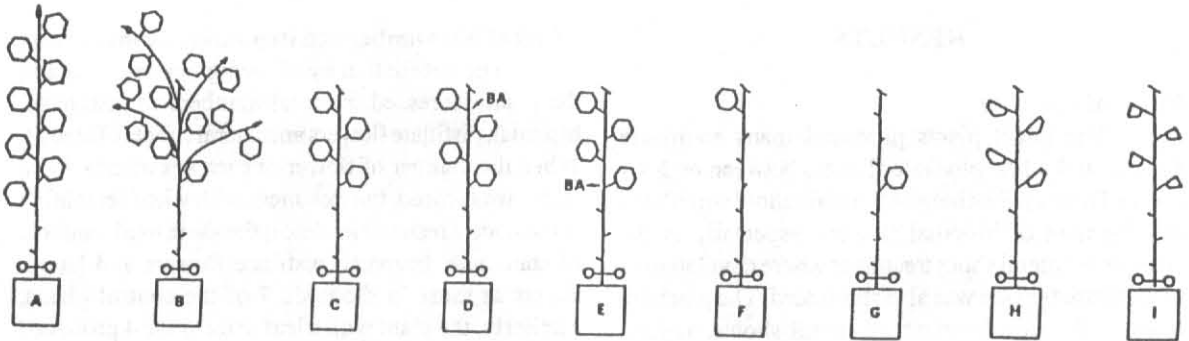

**Figure 1** Shoot of cucumber cv. 'Sagami-hangiro' was kept intact but the first 3 leaves were removed (A), main shoot was pinched above node 7 and lateral shoots were allowed to grow (B), main shoot was pinched and lateral shoots were removed (C), main shoot was pinched and BA was applied at node 7 (D), or at node 4 (E), main shoot was pinched and defoliated remain one leaf at node 7 (F), or node 4 (G), main shoot was pinched and all leaves were cut into half (H), or quarter (I).



**Figure 2** Lateral shoot developed on the plant whose main shoot was pinched in cucumber cv. 'Sagami-hangiro'. Note that the lateral shoot was formed.

node 4, which was very far from pinching position, in the plant with either half or quarter of leaves.

## DISCUSSION

Pinching main shoot of cucumber promoted the formation of bisexual flowers and pistillate flowers. Pinching the main shoot and not removed the lateral shoot showed weaker effects on inducing bisexual and pistillate flowers formation than that in the absence of lateral shoot. The result indicated that auxin at new lateral shoots dominated over axillary bud growth. The transformation of flower sex to bisexual and pistillate flowers in cucumber after pinching the main shoot may be concerned with these processes.

After pinching the main shoot, the auxin which synthesized at axillary buds affected bud growth (Tamas, 1987). The endogenous auxin contents which increased and accumulated at these axillary buds (Bourbouloux and Bonnemain, 1980.) may capable in transformation of these flower buds to bisexual and pistillate flowers. Auxin is known to promote femaleness in most species of Cucurbitaceae plants (Galun *et al.*, 1963).

The other possible mechanism of apical dominance concerns with cytokinin. Cytokinin induced growth of buds of soybean (Ali and Fletcher 1971). Endogenous cytokinin in the strong apical dominance line of tomato was found less than that of the normal line (Mapelli and Lombardi, 1982). Phillips (1975) suggested that apical dominance may be maintained by regulating cytokinin distribution in the plant. Cytokinin was found to be one of the factors regulating femaleness of *Vitis vinefera* (Negi and Olmo, 1971), *Cannabis sativa* (Chailakhyan and Khyranim, 1978a; 1978b), *Cleome iberidella* (De Jong and Bruinsma, 1974), *Asparagus officinalis* (Lazarte and Garrison, 1980) and *Luffa cylindrica* (Takahashi *et al.*, 1980). Matsubara (1977) demonstrated that the addition of cytokinin to the media promoted pistillate organs formation in cucumber cultured *in vitro*. Therefore, BA may influence sex expression in cucumber. In the present experiment, BA was found to induce only pistillate flowers formation but did not effect bisexual flowers formation. Since flower bud of cucumber develops as a bisexual flower (Atsmon and Galun, 1962), the application of BA at this stage may inhibit the development of staminate organ and, hence in-

**Table 3 Effect of leaf number and its position on sex expression of staminate cluster in cucumber, cv. "Sagami hanjiro".<sup>Z</sup>**

Leaf number (Position)	Node <sup>Y</sup>	Total number of				Total
		staminate flowers	bisexual flowers	pistillate flowers	new lateral shoots	
4	7	62±0.71	54±1.94	3±0.30	6±0.16	125±2.92
	6	41±0.30	35±0.71	3±0.15	9±0.18	88±1.24
	5	39±0.38	30±1.26	4±0.30	11±0.23	84±1.39
	4	35±0.40	30±0.85	5±0.22	10±0.35	80±1.24
	Total	177±0.83	149±2.27	15±0.49	36±0.35	377±2.93
1 (Node 4)	7	58±0.52	59±1.02	5±0.16	8±0.13	130±0.89
	6	32±0.82	18±0.98	0±0.00	7±0.15	57±1.57
	5	26±0.49	6±0.26	0±0.00	6±0.21	38±0.85
	4	26±0.67	9±0.58	0±0.00	8±0.13	43±1.13
Total	142±1.43	92±1.56	5±0.16	29±0.47	268±2.45	
1 (Node 4)	7	47±1.05	29±2.04	0±0.00	7±0.21	83±2.79
	6	35±0.78	22±1.13	0±0.00	6±0.16	63±1.70
	5	25±0.40	6±0.22	1±0.09	10±0.15	42±0.54
	4	37±0.32	28±0.34	6±0.15	12±0.23	83±0.74
Total	144±1.37	85±2.33	7±0.14	35±0.45	271±3.82	

Z All the plants were pinched above the 7th node and the values are total numbers per 10 plants of flowers of each sex or lateral shoot ± SE.

Y Counted from the lower part.

**Table 4 Influence of leaf area on sex expression of staminate cluster in cucumber, cv. "Sagami hanjiro".<sup>Z</sup>**

Leaf area	Node <sup>Y</sup>	Total number of				Total
		staminate flowers	bisexual flowers	pistillate flowers	new lateral shoots	
1	7	78+-0.41	81+-0.55	3+-0.09	0+-0.00	162+-1.23
	6	60+-0.78	60+-0.71	2+-0.15	3+-0.41	125+-1.05
	5	65+-1.04	26+-0.33	2+-0.24	3+-0.41	96+-1.89
	4	30+-0.47	22+-0.15	2+-0.15	6+-0.15	60+-1.39
	Total	233+-2.64	189+-1.07	9+-0.28	12+-0.38	443+-4.36
1/2	7	73+-0.65	70+-0.47	0+-0.00	0+-0.00	143+-1.77
	6	60+-0.67	50+-1.00	0+-0.00	5+-0.24	115+-1.14
	5	55+-1.12	38+-0.68	0+-0.00	3+-0.41	96+-1.68
	4	40+-1.18	33+-0.38	2+-0.15	3+-0.41	78+-1.64
	Total	228+-2.83	191+-2.53	2+-0.15	11+-0.45	432+-2.70
1/4	7	78+-0.60	65+-0.61	0+-0.00	3+-0.41	146+-2.53
	6	60+-0.47	48+-1.48	0+-0.00	3+-0.41	111+-1.03
	5	48+-0.51	46+-0.69	0+-0.00	5+-0.24	99+-2.17
	4	30+-0.33	28+-0.28	2+-0.15	5+-0.24	65+-3.03
	Total	216+-0.74	187+-3.21	2+-0.15	16+-0.41	421+-7.04

Z All the plants were pinched above the 7th node and the values are total numbers per 10 plants of flowers of each sex or lateral shoot  $\pm$  SE.

Y Counted from the lower part.

duced pistillate flowers. Woolley and Wareing (1972) showed in decapitated *Solanum andigena* cuttings that cytokinin from roots may be transported and accumulated in axillary buds and caused the buds to grow. Pinching without application of BA induced pistillate flower formation at every node whereas BA induce them only at the cluster to which BA was applied (Table 2). This also indicated that the promotion of pistillate flowers by the pinching and that by BA were through different mechanisms.

Another possible explanation on the effect of the pinching is an influence of the decrease in the number of leaves. Actually the effect of pinching on increasing bisexual and pistillate flowers was weak when the number of leaves remaining on the plant was decreased (Table 3). A possible role of leaves is the production of some unknown substance(s) inducing transformation of flower sex. Some workers speculated that increasing the level of the floral stimulus may promote the transformation of flower sex from staminate to bisexual and pistillate flowers in the Cucurbitaceae species. (Ito and Saito, 1950; Saito, 1961; Takahashi *et al.*, 1982). The degree of transformation from staminate cluster to bisexual or pistillate flowers decreased when the lateral shoots were not

removed. The flowering stimulus may be transferred to shoot apices of the newly developed shoots, and not to the lateral buds of the main stem. This may decrease the ability of the transformation. The decreasing leaf area had no effect on changing the total numbers of staminate and bisexual flowers (Table 4). Therefore, total number of leaves is more important than leaf area in controlling sex transformation in cucumber plant.

#### ACKNOWLEDGEMENT

The authors appreciated the valuable advice from Dr. Krisana Krisanapook of Kasetsart University.

#### LITERATURE CITED

- Ali, A. and R.A. Fletcher. 1971. Hormonal interaction in controlling apical dominance in soybeans. *Can. J. Bot.* 49 : 1727-1731.
- Atsmon, D. and E. Galun. 1962. Physiology of sex in *Cucumis sativus* (L.) leaf age patterns and sexual differentiation of floral buds. *Ann. Bot.* 26 : 137-146.

- Bourbouloux, A.E. and J.L. Bonnemain. 1980. Distribution of labelled auxin and derivatives in stem tissue of intact and decapitated broad-bean plants in relation to apical dominance. *Physiol. Plant.* 50 : 145-152.
- Chailakhyan, M.Kh. and V.K. Khryanin. 1978a. The influence of growth regulators absorbed by the root on sex expression in hemp plants. *Planta* 138 : 181-184.
- Chailakhyan, M.Kh. and V.K. Khryanin. 1978b. The role of roots in sex expression in hemp plants. *Planta* 138 : 185-187.
- De Jong, A.W. and J. Bruinsuma. 1974. Pistil development in *Cleome* flowers III. Effect of growth regulating substances on flower buds of *Cleome iberidella* Welw. ex oliv. grown *in vitro*. *Z. Pflanzen Physiol.* 73 : 142-151.
- Galun, E., Y. Jung, and A. Lang. 1963. Morphogenesis of floral buds of cucumber cultured *in vitro*. *Develop. Biol.* 6 : 370-387.
- Ito, H. and T. Saito. 1960. Factors responsible for the sex expression of the cucumber plant XII Physiological factors associated with the sex expression of flowers. *Tohoku J. Agr. Res.* 11 : 287-308.
- Jacobs, G. 1983. Flowering initiation and development in *Leucospermum* cv. Red Sunset. *J. Amer. Soc. Hort. Sci.* 108 : 32-35.
- Jutamanee, K. and T. Saito. 1992. Physiological analysis of genecological variation in the flower formation and the sex expression of cucumber plants. Spring Meeting Abstr. Jap. Soc. Hort. Sci. pp. 278-279. (in Japanese).
- Khryanin, V.N. and M. Kh. Chailakhyan. 1979. Biological activity of cytokinins and gibberellins in roots and leaves in manifestation of sex in dioecious plants. *Soviet Plant Physiol.* 26 : 814-820.
- Lazarte, J.E. and S.A. Garrison. 1980. Sex modification in *Asparagus officinalis* L. *J. Amer. Soc. Hort. Sci.* 105 : 691-694.
- Mapelli, S. and L. Lombardi. 1982. A comparative auxin and cytokinin study in normal and to-2 mutant tomato plants. *Plant Cell Physiol.* 23 : 751-757.
- Matsubara, S. 1977. *in vitro* modification of sex expression of cucumber by plant growth regulators. *Sci. Rep. Fac. Agr. Okayama Univ.* 49 : 15-23.
- Negi, S.S. and H.P. Olmo. 1971. Induction of sex conversion in male *Vitis*. *Vitis* 10 : 1-19.
- Ombrello, T.M. and S.A. Garrison. 1987. Endogenous gibberellins and cytokinins in spear tips of *Asparagus officinalis* in relation to sex expression. *J. Amer. Soc. Hort. Sci.* 112 : 539-544.
- Phillips, I.D.J. 1975. Apical dominance. *Ann Rev. Plant Physiol.* 26 : 341-367.
- Sachs, T. and K.V. Thimann. 1967. The role of auxins and cytokinins in the release of buds from dominance. *Amer. J. Bot.* 54 : 136-144.
- Saito, T. 1961. Factors responsible for the sex expression of Japanese cucumber. X. Studies on the dark process. *J. Jpn. Soc. Hort. Sci.* 30 : 1-8.
- Saito, T., H. Takahashi, and H. Suge. 1988. Physiological analysis of genecological variation in the sex expression of cucumber plant. *Bull. Yamagata Univ. (Agricultural Science)*. 10 : 621-636. (In Japanese).
- Takahashi, H., H. Suge, and T. Saito. 1980. Sex expression as affected by N<sup>6</sup>-benzylaminopurine in staminate inflorescence of *Luffa cylindrica*. *Plant Cell Physiol.* 21 : 525-536.
- Takahashi, H., T. Saito, and H. Suge. 1982. Intergeneric translocation of floral stimulus across a graft in monoecious cucurbitaceae with special reference to the sex expression of flowers. *Plant Cell Physiol.* 23 : 1-9.
- Tamas, I.A. 1987. Hormonal regulation of apical dominance. pp. 393-410. *In* P.J. Davies (ed.). *Plant Hormones and Their Role in Plant Growth and Development*. Kluwer Academic Publishers, Netherlands.
- Thimann, K.V., T. Sachs, and K.N. Mathur. 1971. The mechanism of apical dominance in *Coleus*. *Physiol. Plant.* 24 : 68-72.
- Woolley, D.J. and P.F. Wareing. 1972. The interaction between growth promoters in apical dominance. I. Hormonal interaction, movement and metabolism of cytokinin in rootless cuttings. *New Phytol.* 71 : 781-793.